

GARMIN G1000 GIA 63W INTEGRATED AVIONICS UNIT - REMOVAL/INSTALLATION

1. General

- A. This section gives the removal and installation procedures for the Garmin G1000 GIA 63W Integrated Avionics Unit. For a general overview of the Garmin G1000 GIA 63W Integrated Avionics Unit refer to Garmin G1000 Integrated Avionics System - Description and Operation.

2. Tools and Equipment

NOTE: For the supplier publication part number and manufacturer data, refer to the Introduction Supplier Publication List.

- A. Tools and Equipment
 - None.
- B. Special Consumables
 - None.
- C. Reference Material
 - Chapter 20, Electrical Bonding - Maintenance Practices
 - Chapter 20, Electrostatic Discharge Components - Maintenance Practices
 - Garmin G1000 Integrated Avionics System - Description and Operation
 - Garmin G1000 Integrated Avionics System - Adjustment/Test.
 - Garmin G1000 GIA 63 Integrated Avionics Unit - Adjustment/Test
 - Garmin Display Unit - Removal/Installation.

3. Setup

- A. Prepare the Airplane
 - (1) Make sure that the BATTERY switch, found on the circuit breaker switch panel, is set to the OFF position.
 - (2) Make sure that the AVIONICS switches, found on the circuit breaker switch panel, are set to the OFF position.
 - (3) Disconnect external electrical power from the airplane.
 - (4) Disengage the applicable circuit breakers given in Table 401.

Table 401. Circuit Breakers

GIA 63W	Circuit Breaker Name	Circuit Breaker Location
GIA 63W Left (No.1)	COM 1	Avionics Circuit Breaker Panel
	NAV 1	Avionics Circuit Breaker Panel
GIA 63W Right (No.2)	COM 2	Avionics Circuit Breaker Panel
	NAV 2	Avionics Circuit Breaker Panel

4. GIA 63W Removal

CAUTION: Be careful when you remove or install electronic components. Electronic components are extremely sensitive to electrostatic discharge damage. Such damage cannot be seen by visual inspection and can make the component unserviceable. Refer to, Chapter 20, Electrostatic Discharge Components - Maintenance Practices for procedures to correctly work with electronic components.

- A. Remove the GIA 63W (Refer to Figure 401).

NOTE: The removal of the GIA 63W No.1 and No. 2 are typical.

(1) As applicable, remove the pilot's (PFD 1) or copilot's (PFD 2) primary flight display. Refer to Garmin Display Unit - Removal/Installation.

- (2) Loosen the captive screw in the GIA 63W lock lever.

NOTE: The screw is captive to the handle, do not remove it from the handle.

- (3) Lift the lock lever to release the GIA 63W from the avionics rack.
- (4) Carefully pull the GIA 63W from the mounting rack.
- (5) Remove the GIA 63W from the airplane.

5. GIA 63W Installation

CAUTION: Be careful when you remove or install electronic components. Electronic components are extremely sensitive to electrostatic discharge damage. Such damage cannot be seen by visual inspection and can make the component unserviceable. Refer to Chapter 20, Electrostatic Discharge Components - Maintenance Practices for procedures to correctly work with electronic components.

A. Install the GIA 63W (Refer to Figure 401).

NOTE: The Installation of the GIA 63W No. 1 and No. 2 is typical.

(1) Make sure that the backplate assembly is installed correctly in the mounting rack.

(2) Install the GIA 63W in the mounting rack as follows:

(a) Make sure that the lock stud is aligned with the lock channel in the mounting rack.

CAUTION: Do not use too much force when you push the GIA 63W in the mounting rack. Too much force can cause damage to the coaxial cable connectors, electrical connectors, GIA 63W, or the mounting rack.

(b) Carefully push the GIA 63W to connect it to the electrical connectors and coaxial connectors contained in the backplate assembly.

(c) Push the lock handle lever down to engage it.

NOTE: This moves the lock stud in the lock channel and locks the GIA 63W in the mounting rack.

(d) Carefully tighten the lock screw on the lock handle lever..

(3) As applicable, remove the pilot's (PFD 1) or copilot's (PFD 2) primary flight display. Refer to Garmin Display Unit - Removal/Installation.

6. GIA 63W Post-Maintenance Checks

A. Do the GIA 63W Post-Maintenance Checks

(1) Engage the circuit breakers applicable to the GIA 63W you replaced given in Table 401.

(2) Do the G1000 Baseline Software/Configuration Load. Refer to Garmin G1000 Integrated Avionics System - Adjustment/Test.

NOTE: No software or configuration loading is required if the removed GIA is reinstalled in its original position (GIA1 and GIA2 in their original racks). This does not include units that were returned for repair as their software and configuration files are deleted during the repair testing process.

(3) If a new GIA 63W is installed, load the options software and applicable configuration files for all the airplane options. Refer to Garmin G1000 Integrated Avionics System - Adjustment/Test G1000 Option Software Load and applicable configuration file upload procedures in that section.

(4) Do a functional check of the GIA 63W. Refer to Garmin G1000 GIA 63 Integrated Avionics Unit - Adjustment/Test.

7. Closeout

A. Put the Airplane Back to its Initial Condition.

(1) None.

Figure 401 : Sheet 1 : GIA 63 Integrated Avionics Unit Installation

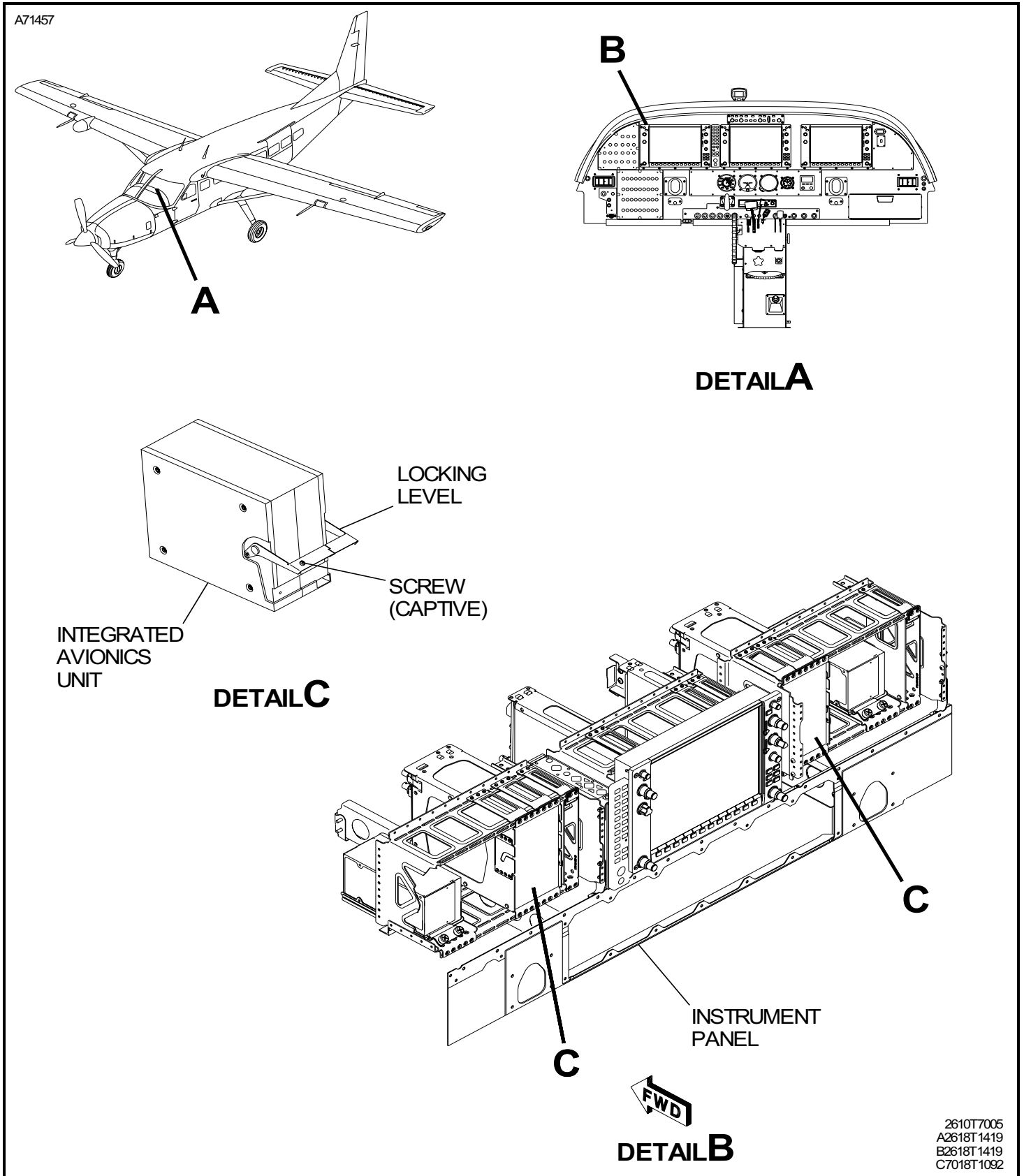

2610T7005
A2618T1419
B2618T1419
C7018T1092